

FEATURES

- Low Noise Constant-Frequency Operation
- Multi-Mode Operation: 1x or 2x Boost Mode
- Automatic Mode Switching
- High Output Current: 150mA (Continuous), 400mA (Pulsed) From Li-Ion/Polymer Input
- 2-Second Flash Current Timeout for LED Protection
- Automatic Soft-Start
- Output Disconnect
- No Inductors
- 220mΩ Internal High Side Current Sense Resistor
- Single Resistor Programming Capability
- Tiny Application Circuit (3mm × 2mm DFN Package, All Components < 1mm High)

APPLICATIONS

- LED Torch/Flash Supply for DSCs/Cellphones

DESCRIPTION

The LTC[®]3218 is a low-noise, high-current charge pump DC/DC converter capable of driving high current LEDs at up to 400mA from a 2.9V to 4.5V input. A low external parts count (one flying capacitor, two programming resistors and two bypass capacitors at V_{IN} and CPO) make the LTC3218 ideally suited for small, battery-powered applications.

Built-in soft-start circuitry prevents excessive inrush current during start-up. High switching frequency enables the use of small external capacitors. A built-in 2-second timer protects the LED during flash mode.

Output current level is programmed by an external resistor. LED current is regulated using an internal high side 220mΩ sense resistor. Automatic mode switching optimizes efficiency by monitoring the voltage across the charge pump and switching modes only when dropout is detected. The part is available in a low profile 3mm × 2mm 10-lead DFN package.

LT, LT, LTC and LTM are registered trademarks of Linear Technology Corporation. All other trademarks are the property of their respective owners. Protected by U.S. Patents, including 6411531.

TYPICAL APPLICATION

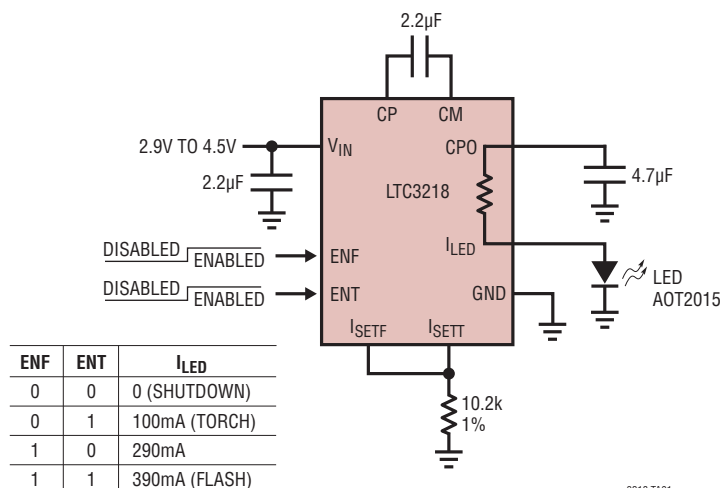

3218 TA01

Efficiency vs V_{IN}

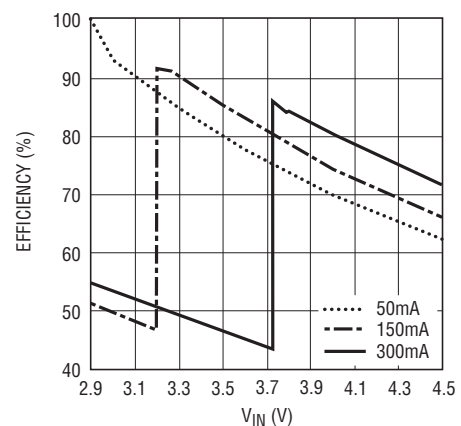

3218 TA01b

ABSOLUTE MAXIMUM RATINGS

(Note 1)

V_{IN} to GND	-0.3V to 6V
CPO to GND	-0.3V to 6V
ENF, ENT	-0.3V to $V_{IN} + 0.3V$
I_{CPO} , I_{LED} (Note 2)	500mA
CPO Short-Circuit Duration	Indefinite
Storage Temperature Range	-65°C to 125°C
Operating Temperature Range (Note 3)	-40°C to 85°C

PIN CONFIGURATION

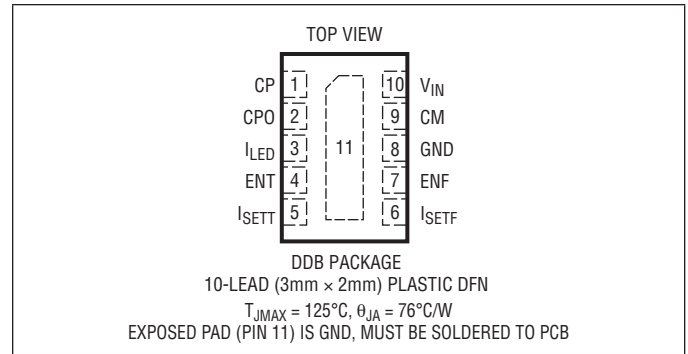

ORDER INFORMATION

LEAD FREE FINISH	TAPE AND REEL	PART MARKING	PACKAGE DESCRIPTION	TEMPERATURE RANGE
LTC3218EDDB#PBF	LTC3218EDDB#TRPBF	LCHS	10-Lead (3mm x 2mm) Plastic DFN	-40°C to 85°C

Consult LTC Marketing for parts specified with wider operating temperature ranges.

Consult LTC Marketing for information on non-standard lead based finish parts.

For more information on lead free part marking, go to: <http://www.linear.com/leadfree/>

For more information on tape and reel specifications, go to: <http://www.linear.com/tapeandreeel/>

ELECTRICAL CHARACTERISTICS The ● denotes the specifications which apply over the full operating temperature range, otherwise specifications are at $T_A = 25^\circ\text{C}$, $V_{IN} = 3.6\text{V}$, $C_{IN} = C_{FLY} = 2.2\mu\text{F}$, $C_{CPO} = 4.7\mu\text{F}$, ENF = HIGH, unless otherwise noted.

PARAMETER	CONDITIONS	MIN	TYP	MAX	UNITS
Input Power Supply					
V_{IN} Operating Voltage		● 2.9		4.5	V
I_{VIN} Operating Current	$I_{CPO} = 0\text{mA}$, 1x Mode $I_{CPO} = 0\text{mA}$, 2x Mode		980 1.7		μA mA
I_{VIN} Shutdown Current	ENF = ENT = LOW, $V_{CPO} = 0\text{V}$	●	1.1	3	μA
LED Current					
Torch Current Ratio (I_{LED}/I_{SET})	$I_{LED} = 50\text{mA}$ ENT = HIGH, ENF = LOW		765 850 935		A/A
Flash Current Ratio (I_{LED}/I_{SET})	$I_{LED} = 150\text{mA}$ ENT = LOW, ENF = HIGH		2205 2450 2695		A/A
Flash Current Ratio (I_{LED}/I_{SET})	$I_{LED} = 150\text{mA}$ ENT = ENF = HIGH		2970 3300 3630		A/A
I_{LED} Dropout Voltage (V_{ILED})	Mode Switching Threshold, $\Delta(V_{CPO} - V_{ILED})$, $I_{LED} = 100\text{mA}$		7		mV
Mode Switching Delay (LED Warm-Up Time)			0.5		ms
Turn-On Time	ENF, ENT_F to LED Current On		160		μs
Minimum LED Forward Voltage	$I_{LED} = 50\text{mA}$	●	2.2		V

ELECTRICAL CHARACTERISTICS The ● denotes the specifications which apply over the full operating temperature range, otherwise specifications are at $T_A = 25^\circ\text{C}$, $V_{IN} = 3.6\text{V}$, $C_{IN} = C_{FLY} = 2.2\mu\text{F}$, $C_{CPO} = 4.7\mu\text{F}$, $ENF = \text{HIGH}$, unless otherwise noted.

PARAMETER	CONDITIONS	MIN	TYP	MAX	UNITS	
Charge Pump (CPO)						
Charge Pump Output Clamp Voltage			5.3		V	
1:1 Mode Output Impedance			1.3		Ω	
1:2 Mode Output Impedance			7		Ω	
CLK Frequency			1		MHz	
CPO Short Circuit Detection						
Threshold Voltage	ENT = HIGH	●	0.6	1.5	V	
Test Current	ENT = ENF = LOW, $V_{CPO} = 0\text{V}$	●	20	50	mA	
ENF, ENT						
High Level Input Voltage (V_{IH})		●	1.4		V	
Low Level Input Voltage (V_{IL})		●		0.4	V	
Input Current (I_{IH})	$V_{EN} = 3.6\text{V}$	●	14.4	30	μA	
Input Current (I_{IL})	$V_{EN} = 0\text{V}$	●	-1	1	μA	
Flash Timeout	ENF = HIGH		2		s	
ISETF, ISETT						
V_{ISET}	$I_{SET} = 110\mu\text{A}$	●	1.18	1.21	1.24	V
I_{ISET}	ENT = LOW, ENF = HIGH	●		181	μA	

Note 1: Stresses beyond those listed under Absolute Maximum Ratings may cause permanent damage to the device. Exposure to any Absolute Maximum Rating condition for extended periods may affect device reliability and lifetime.

Note 2: Based on long-term current density limitations. Assumes an operating duty cycle of $\leq 10\%$ under Absolute Maximum Conditions

for durations less than 10 seconds. Maximum current for continuous operation is 150mA.

Note 3: The LTC3218E is guaranteed to meet performance specifications from 0°C to 85°C . Specifications over the -40°C to 85°C ambient operating temperature range are assured by design, characterization and correlation with statistical process controls.

TYPICAL PERFORMANCE CHARACTERISTICS $T_A = 25^\circ\text{C}$, unless otherwise noted.

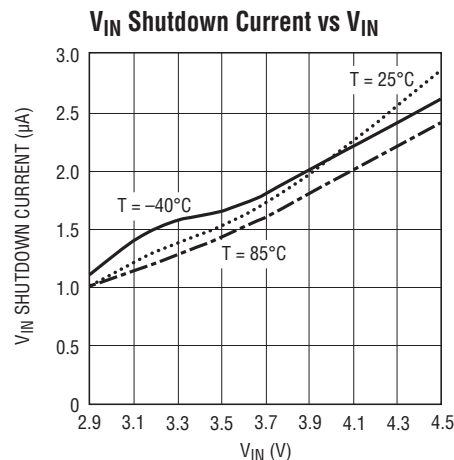
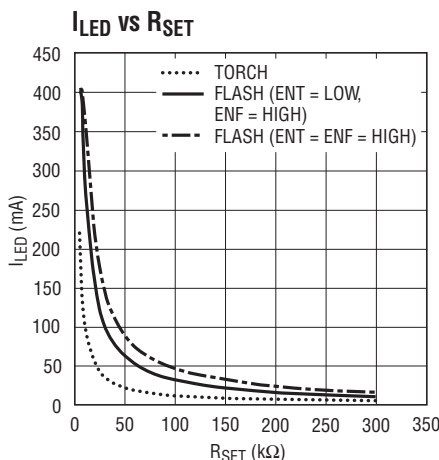
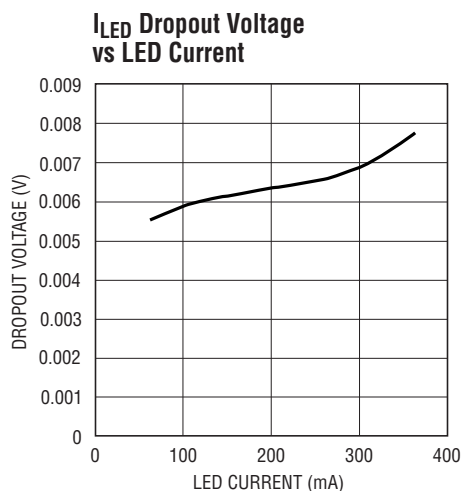

TYPICAL PERFORMANCE CHARACTERISTICS $T_A = 25^\circ\text{C}$, unless otherwise noted.

1x Mode Charge Pump Open-Loop Output Resistance vs Temperature

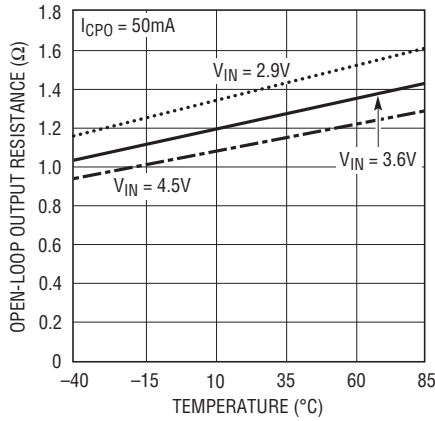

2x Mode Charge Pump Open-Loop Output Resistance $(2V_{IN} - V_{CPO})/I_{CPO}$ vs Temperature

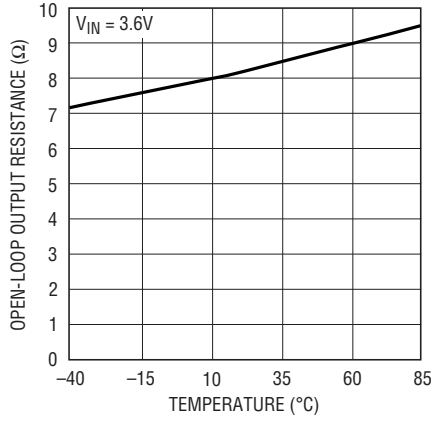

Oscillator Frequency vs V_{IN}

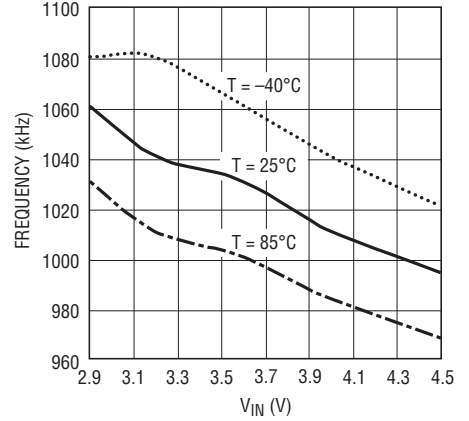

Torch Mode I_{LED}/I_{SET} Current Ratio vs I_{LED} Current

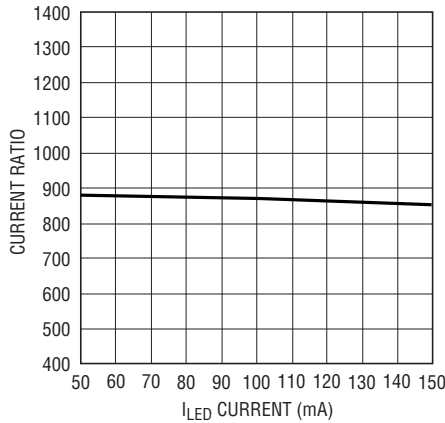

Flash I_{LED}/I_{SET} Current Ratio vs I_{LED} Current (ENT = LOW, ENF = HIGH)

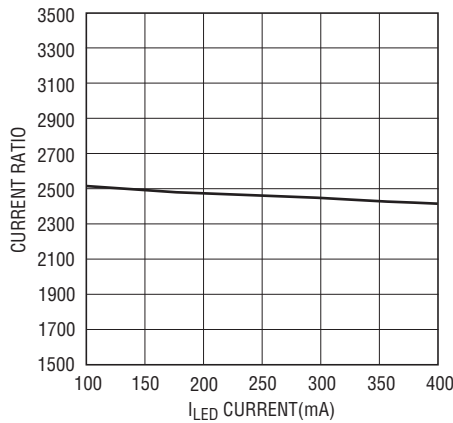

Flash I_{LED}/I_{SET} Current Ratio vs I_{LED} Current (ENT = ENF = HIGH)

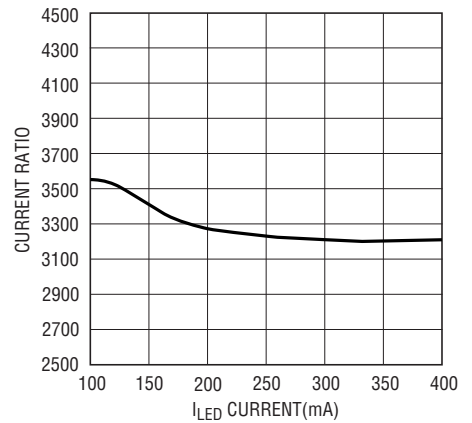

Torch Mode I_{LED} Current vs V_{IN}

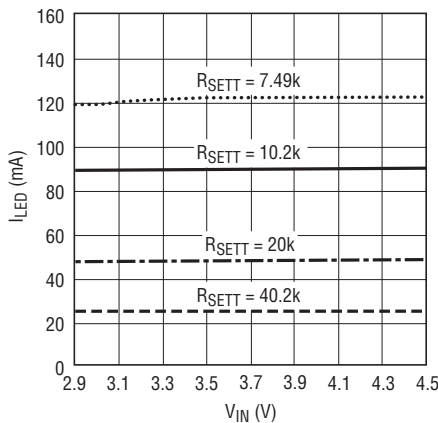

Flash Mode I_{LED} Current vs V_{IN} (ENT = ENF = HIGH)

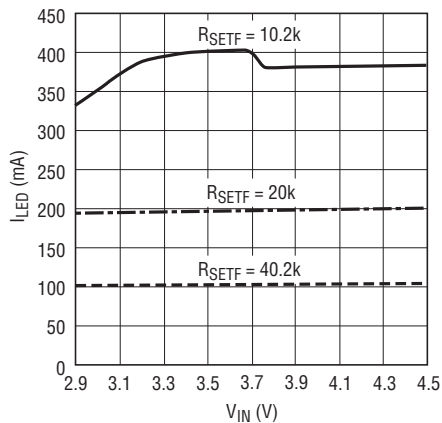

Flash Mode I_{LED} Current vs V_{IN} (ENT = LOW, ENF = HIGH)

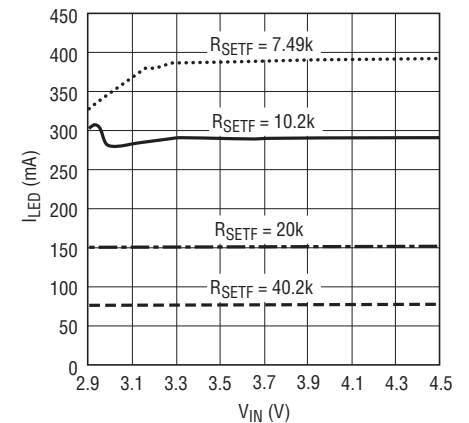

TYPICAL PERFORMANCE CHARACTERISTICS $T_A = 25^\circ\text{C}$, unless otherwise noted.

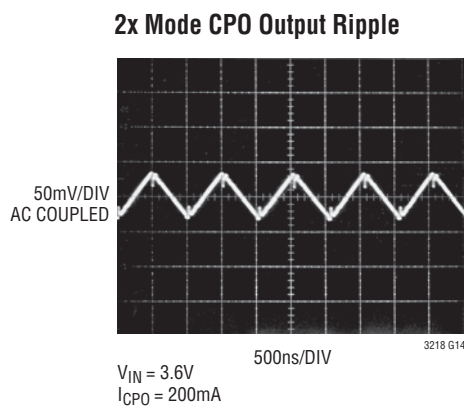
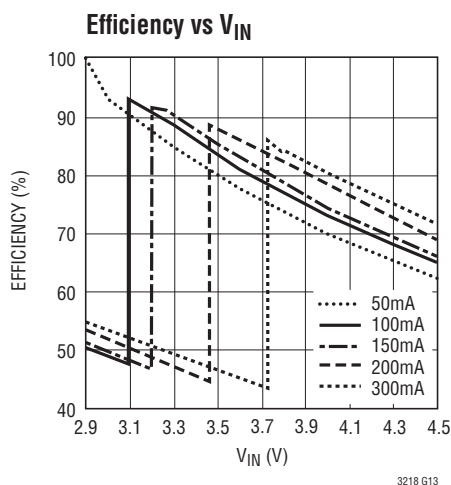

PIN FUNCTIONS

CP, CM (Pin 1, Pin 9): Charge Pump Flying Capacitor. A $2.2\mu\text{F}$ X5R or X7R ceramic capacitor should be connected from CP to CM.

CPO (Pin 2): Output of the Charge Pump. This pin may be enabled or disabled using the ENT and ENF inputs. A $4.7\mu\text{F}$ X5R or X7R ceramic capacitor is required from CPO to GND.

I_{LED} (Pin 3): LED Current Output. The LED is connected between I_{LED} (anode) and GND (cathode). The current out of the I_{LED} pin is set by resistors connected to the I_{SETT} and I_{SETF} pins. An internal, $220\text{m}\Omega$ sense resistor is connected between CPO and I_{LED} .

ENT (Pin 4): Input. The ENT pin is used to enable the part into torch mode and bring it into shutdown mode. An internal $250\text{k}\Omega$ resistor pulls this pin to GND when left floating.

I_{SETT} (Pin 5): LED Torch Current Programming Resistor. A resistor connected between this pin and GND is used to set the LED torch current level.

I_{SETF} (Pin 6): LED Flash Current Programming Resistor. A resistor connected between this pin and GND is used to set the LED flash current level.

ENF (Pin 7): Input. The ENF pin is used to enable the part into flash mode and bring it into shutdown mode. An internal $250\text{k}\Omega$ resistor pulls this pin to GND when left floating. A safety timer will disable the part if this pin is held high for more than 2 seconds.

GND (Pin 8): Ground. This pin should be connected directly to a low impedance ground plane.

V_{IN} (Pin 10): Power. Supply voltage for the LTC3218. V_{IN} should be bypassed with a low impedance ceramic capacitor to GND of at least $1.6\mu\text{F}$ of capacitance.

Exposed Pad (Pin 11): Ground. This pad must be soldered to a low impedance ground plane for optimum thermal performance.

BLOCK DIAGRAM

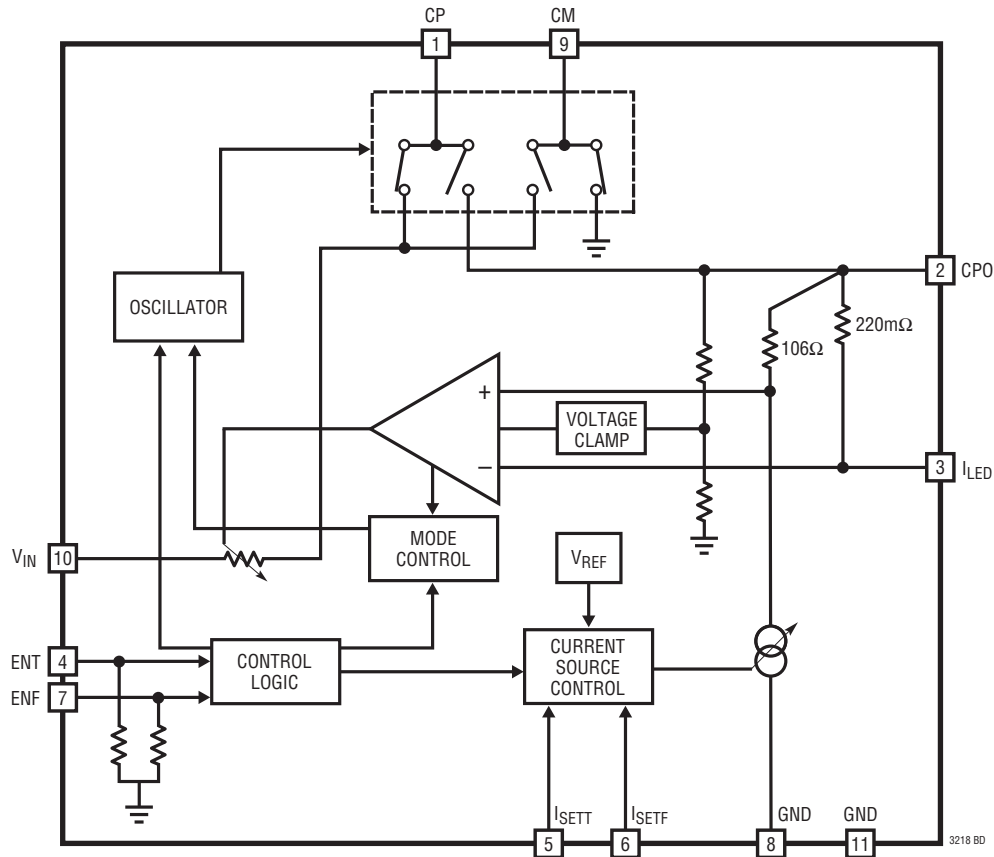

OPERATION

The LTC3218 uses a switched capacitor charge pump to power a high current LED with a programmed regulated current. Current regulation is achieved using an internal current sense resistor connected between the CPO and I_{LED} pins. The part starts up in 1x mode after a soft-start period. In this mode, V_{IN} is connected to the CPO through switches, the strengths of which are modulated to achieve the desired LED current. This mode provides maximum efficiency and minimum noise. The LTC3218 will remain in

this mode until the LED forward voltage (V_F) approaches the maximum CPO voltage possible in this mode. When this dropout condition occurs, the LTC3218 will switch to 2x mode after a soft-start period.

The current delivered to the LED load is controlled by the internal programmable current source. The current is programmed by resistors connected between the I_{SETT} and I_{SETF} pins and GND. The resistor values needed to

OPERATION

attain the desired current level can be determined by Equations 1 and 2:

$$R_{SETF} = \frac{3300 \cdot 1.21V}{I_{LED}} \quad (1)$$

$$R_{SETT} = \frac{850 \cdot 1.21V}{I_{LED}} \quad (2)$$

Overcurrent shutdown mode will prevent damage to the part and LED by shutting down the high power sections of the chip. Choosing an R_{SETF} or R_{SETT} value of 5k or greater will ensure that the part stays out of this mode.

Regulation is achieved by sensing the voltage at the I_{LED} pin and modulating the charge pump strength based on the error signal.

In shutdown mode all circuitry is turned off and the LTC3218 draws a very low current from the V_{IN} supply. The output is disconnected from V_{IN} and is pulled down by a resistance of approximately 90k Ω . The LTC3218 enters shutdown mode when the ENF and ENT pins are brought low.

LED Current Programming

The LTC3218 includes an accurate, programmable current source that is capable of driving LED currents up to 150mA continuously and up to 400mA for pulsed operation. Pulsed operation may be achieved by toggling the ENT or ENF pins. In either continuous or pulsed operation, proper board layout is required for effective heat sinking.

The output current of the LTC3218 is programmed using external resistors connected between the I_{SETT} and I_{SETF} pins and GND. The output current modes are shown in Table 1, where R_{SETT} is connected between I_{SETT} and GND, and R_{SETF} is connected between I_{SETF} and GND.

Since the LTC3218 has three separate LED current ratios built in, it can be programmed using a single resistor by connecting I_{SETT} and I_{SETF} together, and then connecting the pins to the resistor.

Table 1. Output Current Modes for All ENT and ENF Settings

ENF	ENT	I_{LED}
LOW	LOW	SHUTDOWN
LOW	HIGH	$1029/R_{SETT}$
HIGH	LOW	$2965/R_{SETF}$
HIGH	HIGH	$3993/R_{SETF}$

Thermal Protection

The LTC3218 has built-in overtemperature protection. Thermal shutdown circuitry will shut down the part when the junction temperature exceeds approximately 165°C. It will re-enable the part once the junction temperature drops back to approximately 150°C. The LTC3218 will cycle in and out of thermal shutdown indefinitely without latchup or damage until the heat source is removed.

ENF Timeout

The ENF input is used to select the high current setting for use as a camera flash. To prevent damage to the LED, the ENF pin has a 2-second timeout. If the LTC3218 is enabled for greater than approximately 2 seconds using the ENF pin, the part will enter a low-power mode, preventing current from being delivered to the LED. Normal operation can be restored by bringing the part into shutdown and re-enabling it.

Short-Circuit Protection

When ENF or ENT are brought high, the part will connect V_{IN} and CPO through a weak pull-up. If the CPO capacitor fails to charge up to over 1V (i.e., CPO is shorted), the chip will not be enabled. Similarly, during operation if CPO is pulled down below 1V, the part will be disabled.

Soft-Start

To prevent excessive inrush current during start-up and mode switching, the LTC3218 employs built-in soft-start circuitry. Soft-start is achieved by increasing the amount of current available to the output charge storage capacitor linearly over a period of approximately 80 μ s.

OPERATION

Charge Pump Strength

When the LTC3218 operates in 2x mode, the charge pump can be modeled as a Thevenin-equivalent circuit to determine the amount of current available from the effective input voltage and effective open-loop output resistance, R_{OL} (Figure 1).

R_{OL} is dependent on a number of factors including the oscillator frequency, flying capacitor values and switch resistances. From Figure 1, we can see that the output current is proportional to:

$$\frac{2V_{IN} - CPO}{R_{OL}} \quad (3)$$

in 2x mode.

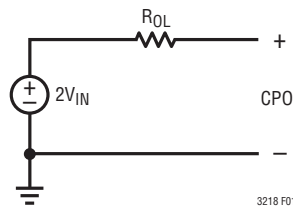

Figure 1. Charge Pump Open-Loop Thevenin-Equivalent Circuit

APPLICATIONS INFORMATION

V_{IN} , CPO Capacitor Selection

The value and type of capacitors used with the LTC3218 determine several important parameters such as regulator control loop stability, output ripple, charge pump strength and minimum start-up time.

To reduce noise and ripple, it is recommended that low equivalent series resistance (ESR) ceramic capacitors be used for both C_{VIN} and C_{CPO} . Tantalum and aluminum capacitors are not recommended because of their high ESR.

The value of C_{CPO} directly controls the amount of output ripple for a given load current. Increasing the size of C_{CPO} will reduce the output ripple at the expense of higher start-up current. The peak-to-peak output ripple for 2x mode is approximately given by the expression:

$$V_{RIPPLE(P-P)} = \frac{I_{OUT}}{2f_{OSC} \cdot C_{CPO}}$$

Mode Switching

The LTC3218 will automatically switch from 1x mode to 2x mode whenever the LED forward voltage approaches the maximum CPO voltage for that mode. The part will wait approximately 500 μ s before switching to the next mode. This delay allows the LED to warm up and reduce its forward voltage which may remove the dropout condition. The part may be reset to 1x mode by bringing the part into shutdown by setting the ENF and ENT pins low. Once these pins are low, either one or both may be immediately brought high to re-enable the part.

Where f_{OSC} is the LTC3218's oscillator frequency (typically 1MHz) and C_{CPO} is the output storage capacitor.

Both the style and value of the output capacitor can significantly affect the stability of the LTC3218. As shown in the Block Diagram, the LTC3218 uses a control loop to adjust the strength of the charge pump to match the current required at the output. The error signal of this loop is stored directly on the output charge storage capacitor. The charge storage capacitor also serves as the dominant pole for the control loop. To prevent ringing or instability, it is important for the output capacitor to maintain at least 3 μ F of actual capacitance over all conditions.

Likewise, excessive ESR on the output capacitor will tend to degrade the loop stability of the LTC3218. To prevent poor load transient response and instability, the ESR of the output capacitor should be kept below 80m Ω . Multilayer ceramic chip capacitors typically have exceptional ESR

APPLICATIONS INFORMATION

performance. MLCCs combined with a tight board layout will yield very good stability. As the value of C_{CP0} controls the amount of output ripple, the value of C_{VIN} controls the amount of ripple present at the input pin (V_{IN}). The input current to the LTC3218 will be relatively constant while the charge pump is on either the input charging phase or the output charging phase but will drop to zero during the clock nonoverlap times. Since the nonoverlap time is small (~15ns), these missing “notches” will result in only a small perturbation on the input power supply line. Note that a higher ESR capacitor such as tantalum will have higher input noise due to the input current change times the ESR. Therefore, ceramic capacitors are again recommended for their exceptional ESR performance. Input noise can be further reduced by powering the LTC3218 through a very small series inductor as shown in Figure 2. A 10nH inductor will reject the fast current notches, thereby presenting a nearly constant current load to the input power supply. For economy, the 10nH inductor can be fabricated on the PC board with about 1cm (0.4”) of PC board trace.

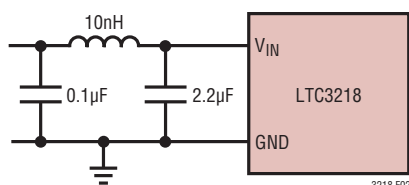

Figure 2. 10nH Inductor Used for Input Noise Reduction (Approximately 1cm of Wire)

Flying Capacitor Selection

Warning: Polarized capacitors such as tantalum or aluminum should never be used for the flying capacitors since their voltage can reverse upon start-up of the LTC3218. Ceramic capacitors should always be used for the flying capacitors.

The flying capacitor controls the strength of the charge pump. In order to achieve the rated output current it is necessary to have at least 1.6µF of actual capacitance for the flying capacitor. Capacitors of different materials lose their capacitance with higher temperature and voltage at different rates. For example, a ceramic capacitor made of X7R material will retain most of its capacitance from -40°C

to 85°C whereas a Z5U or Y5V style capacitor will lose considerable capacitance over that range. Z5U and Y5V capacitors may also have a very poor voltage coefficient causing them to lose 60% or more of their capacitance when the rated voltage is applied. Therefore, when comparing different capacitors, it is often more appropriate to compare the amount of achievable capacitance for a given case size rather than comparing the specified capacitance value. For example, over rated voltage and temperature conditions, a 1µF, 10V, Y5V ceramic capacitor in a 0603 case may not provide any more capacitance than a 0.22µF, 10V, X7R available in the same case. The capacitor manufacturer’s data sheet should be consulted to determine what value of capacitor is needed to ensure minimum capacitances at all temperatures and voltages.

Table 1 shows a list of ceramic capacitor manufacturers and how to contact them.

Table 1. Recommended Capacitor Vendors

AVX	www.avxcorp.com
Kemet	www.kemet.com
Murata	www.murata.com
Taiyo Yuden	www.t-yuden.com
Vishay	www.vishay.com
TDK	www.tdk.com

Layout Considerations and Noise

Due to the high switching frequency and the transient currents produced by the LTC3218, careful board layout is necessary. A true ground plane and short connections to all capacitors will improve performance and ensure proper regulation under all conditions. An example of such a layout is shown in Figure 3.

The flying capacitor pins, CP and CM, will have very high edge rate waveforms. The large dv/dt on these pins can couple energy capacitively to adjacent PCB runs. Magnetic fields can also be generated if the flying capacitors are not close to the LTC3218 (i.e., the loop area is large). To decouple capacitive energy transfer, a Faraday shield may be used. This is a grounded PCB trace between the sensitive node and the LTC3218 pins. For a high quality AC ground, it should be returned to a solid ground plane that extends all the way to the LTC3218.

APPLICATIONS INFORMATION

The following guidelines should be followed when designing a PCB layout for the LTC3218.

- The Exposed Pad should be soldered to a large copper plane that is connected to a solid, low impedance ground plane using plated, through-hole vias for proper heat sinking and noise protection.
- Input and output capacitors (C_{IN} and C_{CPO}) must also be placed as close to the part as possible.
- The flying capacitor must also be placed as close to the part as possible. The traces running from the pins to the capacitor pads should be as wide as possible.
- V_{IN} , CPO and I_{LED} traces must be made as wide as possible. This is necessary to minimize inductance, as well as provide sufficient area for high current applications.
- LED pads must be large and should be connected to as much solid metal as possible to ensure proper heat sinking.

Power Efficiency

To calculate the power efficiency (η) of a white LED driver chip, the LED power should be compared to the input power. The difference between these two numbers represents lost power whether it is in the charge pump or the sense resistor. Stated mathematically, the power efficiency is given by:

$$\eta \equiv \frac{P_{LED}}{P_{IN}}$$

The efficiency of the LTC3218 depends on the mode in which it is operating. In 1x mode, the LTC3218 regulates the output down to the LED forward voltage required to achieve the desired current by varying the strength of the series switches. This mode provides the optimum efficiency available for a given input voltage and LED forward voltage. The efficiency is approximated by:

$$\eta \equiv \frac{P_{LED}}{P_{IN}} = \frac{V_{LED} \cdot I_{LED}}{V_{IN} \cdot I_{IN}} \approx \frac{V_{LED}}{V_{IN}}$$

since the input current will be very close to the LED current.

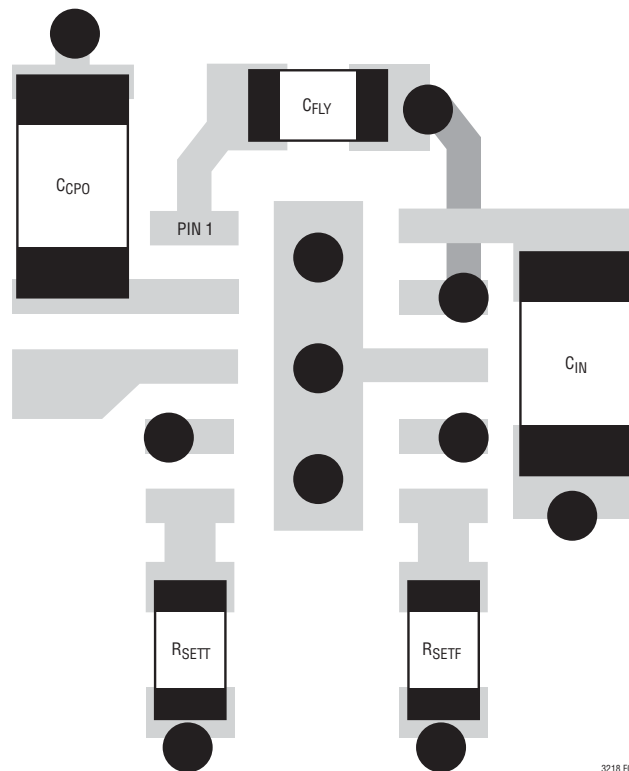

Figure 3. Example Board Layout

APPLICATIONS INFORMATION

At moderate to high output power, the quiescent current of the LTC3218 is negligible and the expression above is valid.

Once dropout is detected at the I_{LED} pin, the LTC3218 enables the charge pump in 2x mode.

In 2x boost mode, the efficiency is similar to that of a linear regulator with an effective input voltage of 2 times the actual input voltage. In an ideal 2x charge pump, the power efficiency would be given by:

$$\eta_{IDEAL} \equiv \frac{P_{LED}}{P_{IN}} = \frac{V_{LED} \cdot I_{LED}}{V_{IN} \cdot 2 \cdot I_{LED}} \approx \frac{V_{LED}}{2V_{IN}}$$

Thermal Management

For higher input voltages and maximum output current, there can be substantial power dissipation in the LTC3218. If the junction temperature increases above approximately 165°C, the thermal shutdown circuitry will automatically deactivate the output. To reduce maximum junction temperature, a good thermal connection to the PC board is recommended. Connecting the Exposed Pad to a ground plane and maintaining a solid ground plane under the device can reduce the thermal resistance of the package and PC board considerably.

PACKAGE DESCRIPTION

DDB Package
10-Lead Plastic DFN (3mm × 2mm)
 (Reference LTC DWG # 05-08-1722 Rev 0)

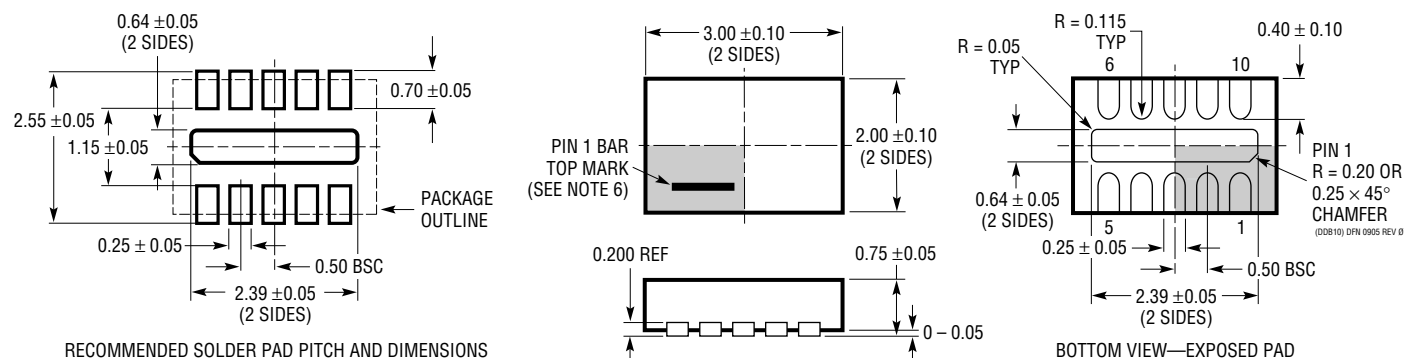

NOTE:

1. DRAWING CONFORMS TO VERSION (WECD-1) IN JEDEC PACKAGE OUTLINE M0-229
2. DRAWING NOT TO SCALE
3. ALL DIMENSIONS ARE IN MILLIMETERS
4. DIMENSIONS OF EXPOSED PAD ON BOTTOM OF PACKAGE DO NOT INCLUDE MOLD FLASH. MOLD FLASH, IF PRESENT, SHALL NOT EXCEED 0.15mm ON ANY SIDE
5. EXPOSED PAD SHALL BE SOLDER PLATED
6. SHADED AREA IS ONLY A REFERENCE FOR PIN 1 LOCATION ON THE TOP AND BOTTOM OF PACKAGE

RELATED PARTS

ENF	ENT	I _{LED}
0	0	0 (SHUTDOWN)
0	1	50mA (TORCH)
1	0	260mA
1	1	350mA (FLASH)

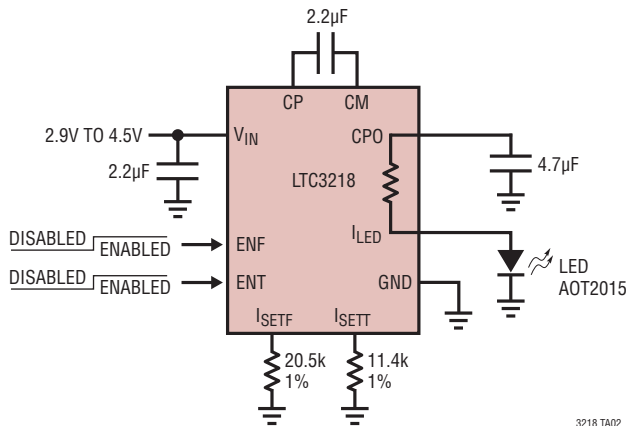

3218 TA02

RELATED PARTS

PART NUMBER	DESCRIPTION	COMMENTS
LTC3200-5	Low Noise, 2MHz Regulated Charge Pump White LED Driver	Up to 6 White LEDs, V _{IN} : 2.7V to 4.5V, V _{OUT(MAX)} = 5V, I _Q = 8mA, I _{SD} ≤ 1µA, ThinSOT™ Package
LTC3201	Low Noise, 1.7MHz Regulated Charge Pump White LED Driver	Up to 6 White LEDs, V _{IN} : 2.7V to 4.5V, V _{OUT(MAX)} = 5V, I _Q = 6.5mA, I _{SD} ≤ 1µA, 10-Lead MS Package
LTC3202	Low Noise, 1.5MHz Regulated Charge Pump White LED Driver	Up to 8 White LEDs, V _{IN} : 2.7V to 4.5V, V _{OUT(MAX)} = 5V, I _Q = 5mA, I _{SD} ≤ 1µA, 10-Lead MS Package
LTC3205	Multidisplay LED Controller	92% Efficiency, V _{IN} : 2.8V to 4.5V, I _Q = 50µA, I _{SD} ≤ 1µA, 4mm × 4mm QFN Package
LTC3206	I ² C Multidisplay LED Controller	92% Efficiency, 400mA Continuous Output Current. Up to 11 White LEDs in 4mm × 4mm QFN Package
LTC3208	High Current Software Configurable Multidisplay LED Controller	95% Efficiency, V _{IN} : 2.9V to 4.5V, V _{OUT(MAX)} : 5.5V, I _Q = 280µA, I _{SD} < 1µA, 5mm × 5mm QFN-32 Package
LTC3209	600mA MAIN/CAM LED Controller	Up to 8 LEDs, 94% Efficiency, V _{IN} : 2.9V to 4.5V, 1x/1.5x/2x Boost Modes, 4mm × 4mm QFN Package
LTC3210/ LTC3210-1	500mA MAIN/Camera LED Controller	Up to 5 LEDs, 95% Efficiency, V _{IN} : 2.9V to 4.5V, 1x/1.5x/2x Boost Modes, Exponential Brightness Control, "-1" Version Has 64-Step Linear Brightness Control, 3mm × 3mm QFN Package
LTC3210-2	MAIN/CAM LED Controller with 32-Step Brightness Control	Drives 4 MAIN LEDs, 3mm × 3mm QFN Package
LTC3210-3	MAIN/CAM LED Controller with 32-Step Brightness Control	Drives 3 MAIN LEDs, 3mm × 3mm QFN Package
LTC3214	500mA Camera LED Charge Pump	94% Efficiency, V _{IN} : 2.9V to 4.5V, I _Q = 300µA, I _{SD} < 2.5µA, 500mA Output Current, 10-Lead 3mm × 3mm DFN Package
LTC3215	700mA Low Noise High Current LED Charge Pump	V _{IN} : 2.9V to 4.4V, V _{OUT(MAX)} = 5.5V, I _Q = 300µA, I _{SD} < 2.5µA, 3mm × 3mm DFN Package
LTC3216	1A Low Noise High Current White LED Driver	93% Efficiency, 1A Output Current, 12-Lead 3mm × 4mm DFN Package, Independent Low/High Current Programming
LTC3217	600mA Low Noise Multi-LED Camera Light	V _{IN} : 2.9V to 4.4V, I _Q = 400µA, Four Outputs, 3mm × 3mm 16-Lead DFN Package
LTC3251	500mA (I _{OUT}), 1MHz to 1.6MHz Spread Spectrum Step-Down Charge Pump	85% Efficiency, V _{IN} : 3.1V to 5.5V, V _{OUT} : 0.9V to 1.6V, I _Q = 9µA, I _{SD} ≤ 1µA, 10-Lead MS Package
LTC3440	600mA (I _{OUT}), 2MHz Synchronous Buck-Boost DC/DC Converter	95% Efficiency, V _{IN} : 2.5V to 5.5V, V _{OUT(MIN)} = 2.5V, I _Q = 25µA, I _{SD} ≤ 1µA, 10-Lead MS Package

ThinSOT is a trademark of Linear Technology Corporation.

3218fb